

Switch Stands and Components

MODELS 50 AND MODELS 51

Model 51 stands are available in the low profile (Model 51A) and intermediate profile (Model 51B). Rugged construction, ease of operation, and nearly a century of proven reliability makes the Switch Stands an excellent choice for use on main lines, sidings, and yard tracks.

Switch Stands are made in two designs: Model 50 (non-adjustable) and Model 51 (adjustable).

In the Model 50, the switch adjustment is made at the connecting rod.

In the Model 51, there is a convenient, selective adjustment feature. By the use of shims in the adjustment slot, either switch point may be adjusted independently of each other.

Switch Stands Models 50 and 51 are made in two types – low and intermediate. The low type distinguished by the letter “A” following the model number; the intermediate type by the letter “B” after the number.

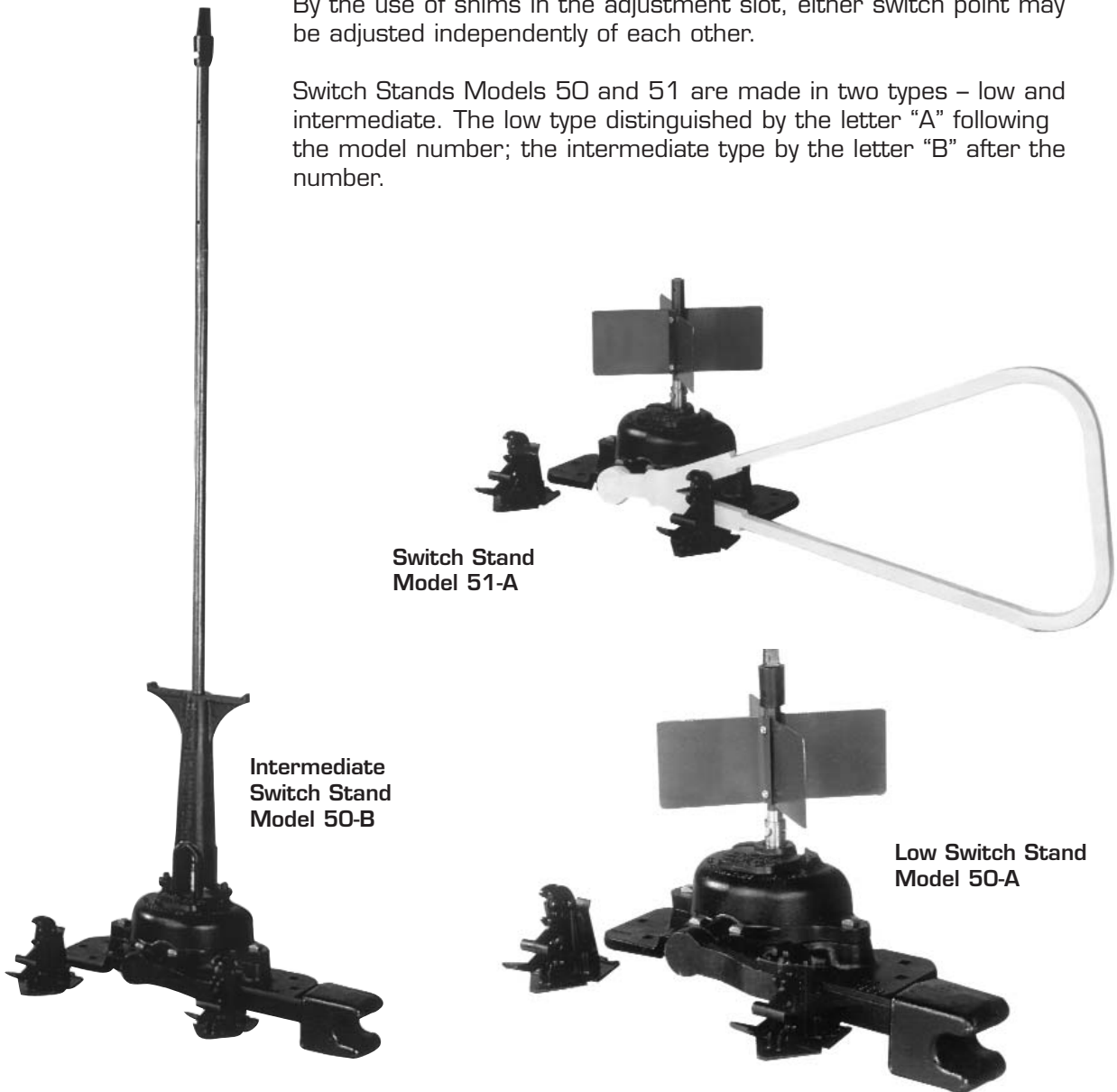

Switch Stands

MODEL 51

Model 51 stands are available in the low type (model 51A) and intermediate (model 51B). Rugged construction and ease of operation make them an excellent choice for use on main lines, sidings, and yard tracks.

Switch points can be adjusted independently of each other by use of shims(see drawing). The weighted throw lever assures positive closing of the switches when engaged with the foot latches.

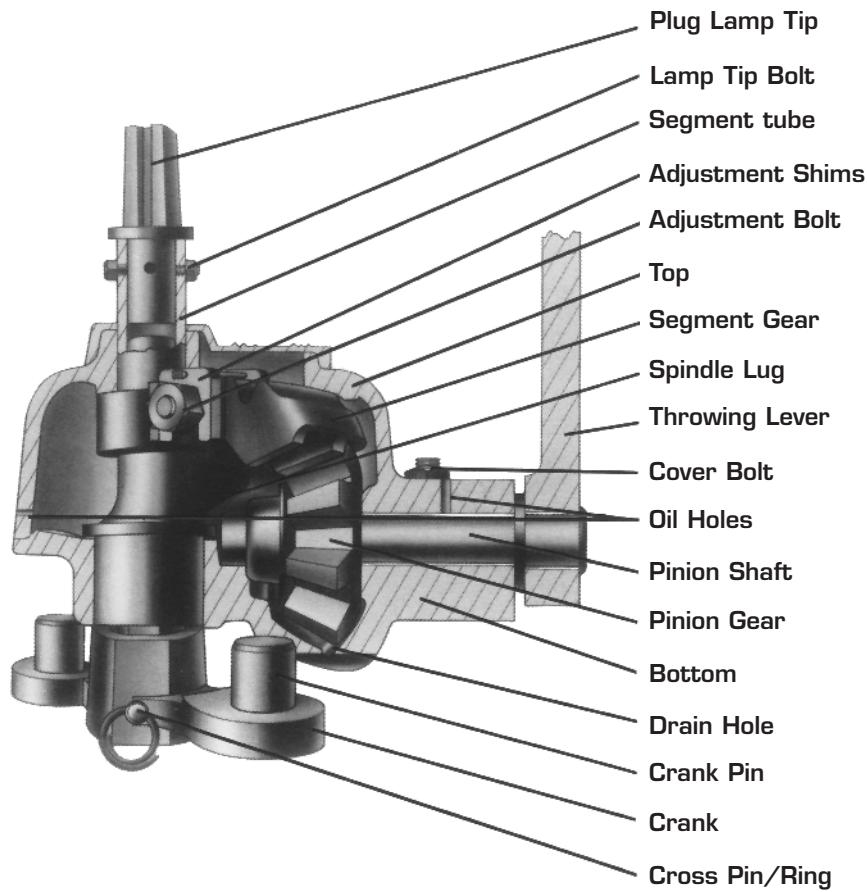

Model 51-B

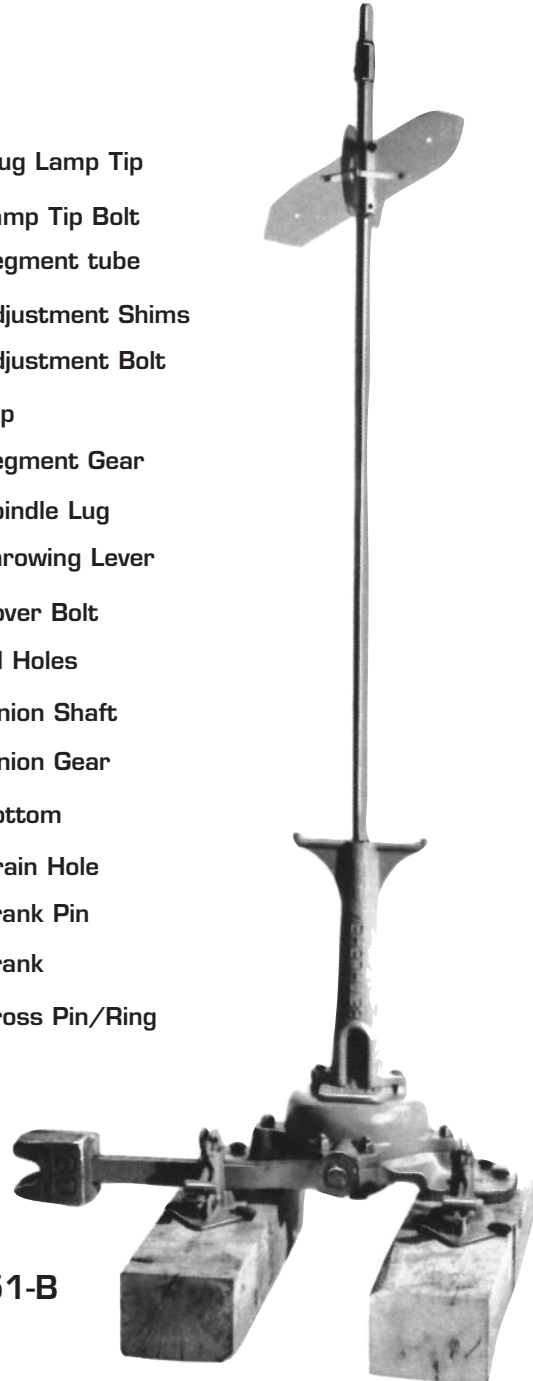

Switch Stands

Model 51-A
(with housing removed)

New and reconditioned
parts available

Adjustment Shims

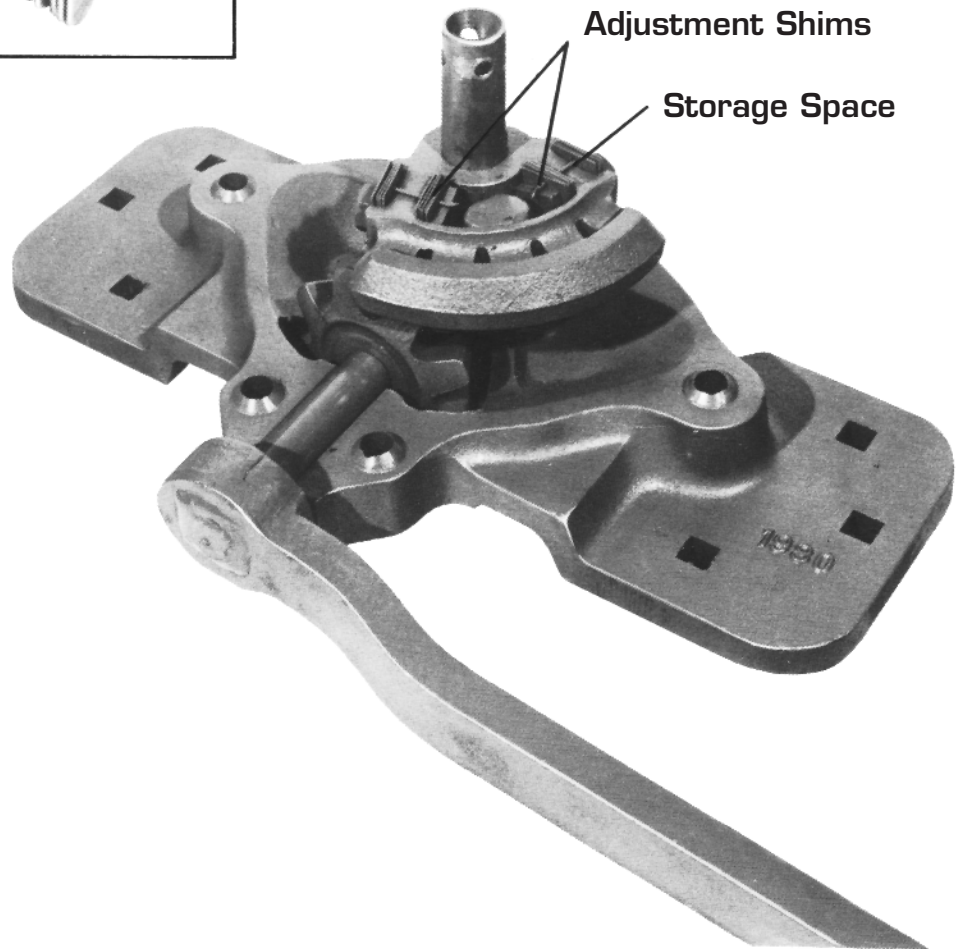
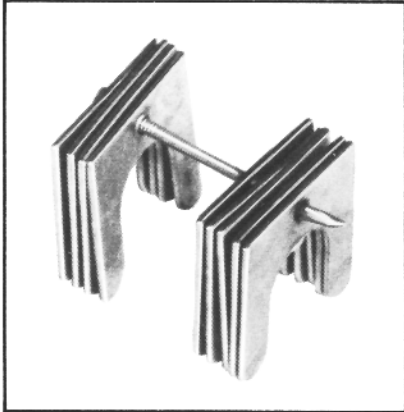

Stand Components

Flat Top SSN 290
For use on models 50-B,
51-A & 51-B
Made of cast iron.



Forged Crank SSN 251



Adjustable Shim Set SSN 210
For use on
models 51-A,51-B



Cover SSN 200
For use on models
51-A & 51-B. Made
of malleable iron.



Breakable Crank SSN 250



SSN 220
For use on Switch
Stands. Made of
forged steel.



Ring SSN 994
This ring serves
as a lock for
cross pin.



Cross Pin SSN 994
Special Shear-resistant
steel.



Adjustment Bolt SSN 996
For use on
Models 51-A
and 51-B



Adjustable Gear Segment SSN 300
For use on Model 51-A.
Made of malleable iron.



Latch Stand SSN 230
For use on all
switch stands.



Bottom SSN 295
For use on all Switch
Stands. Wide, heavy
base of cast iron.



Bow Handle SSN 223
For use on all Switch Stands.
Optional colors available.



Top Extension SSN 292
For mast support on
switch stand models
50-B and 51-B



Throwing Lever SSN 225
A rolled steel lever, assembled
with pinion gear for Models 50
and 51. 30 pound cast iron
weighted handle.



Stand Components

Plug Lamp Tip SSN 270

For use with low stands. The plug lamp tip fits directly into the segment tube on top of the stand and takes the place of the usual target mast. The target used is correspondingly low.



Socket Lamp Tip SSN 270

For use over the mast on low or intermediate stands. The socket end fits over the top of the mast.



Target Masts SSN 280

For Low Models 50-A and 51-A.
Length: 1' 0⁵/₈"



Targets for 51-A SSN 240

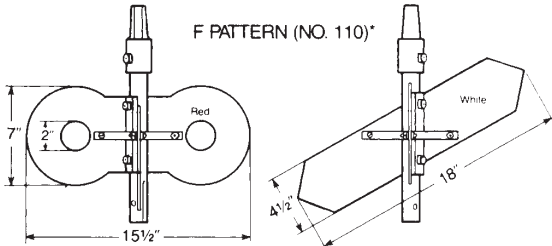

Connecting Rods for 51-A SSN 260



Model 11AN



Model 11TN



Switch Stands

MODEL 22

Model 22 is an ideal switch stand for busy yard and ladder locations where the switch stand is likely to be run through. When the switch is run through, the flange of the wheel partially opens the switch points and then an internal spring takes over and completes the throw. This prevents damage to the switch structure that will occur during a run through on stands that do not have this trailing feature. Also, as an added safety feature, the change of position of the points occurs without the handle of the switch stand ever moving. Available new or fully recondition, with or without rod and target.

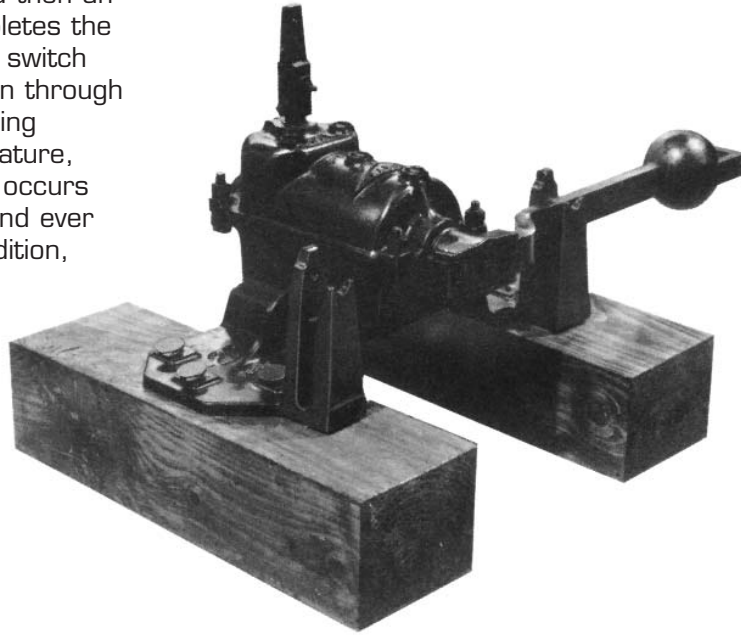

MODEL 112E

The Model 112E switch stand is a sturdy, high parallel throw, two tie stand. You can adjust your throw by turning the forged steel crank eye thus assuring proper setting of the switch points.

This design is simple, rugged, easily inspected and ideal for mainline applications. Available new or reconditioned, with or without rod and target.

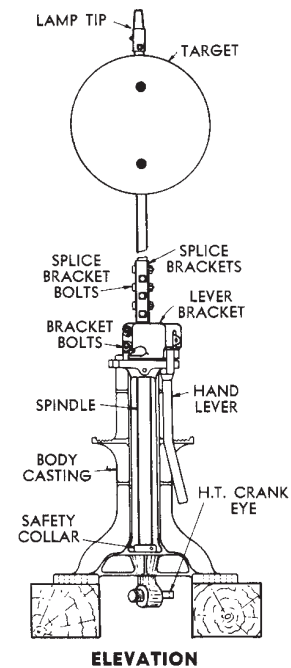
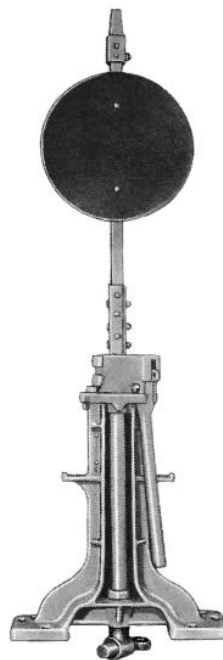

Switch Stands

Models 22-E & 22-EH

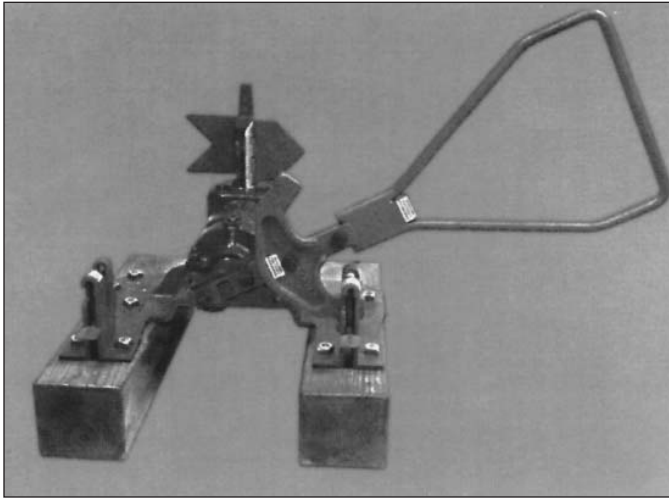

The Model 22-E and 22-EH are ergonomically engineered, extra-heavy-duty trailable switch stands. The low stand 22-E is for yard, ladder and busy switch turnouts, where trains often run through switches. The 22-EH is constructed of identical base housing and operating parts, but features a high mast and target, providing increases visibility where needed.

Ergonomic Design for Operator Safety

The distinct “triangular hand lever has a grasp point that is 30” above ground, helping to prevent painful bending and lifting. Also, the typical 180° movement for the lever has been reduced to 125°, so the switch can be thrown with minimal operator motion. Together, these ergonomically engineered features will help to assure safety for the operator.

Model 22-EH

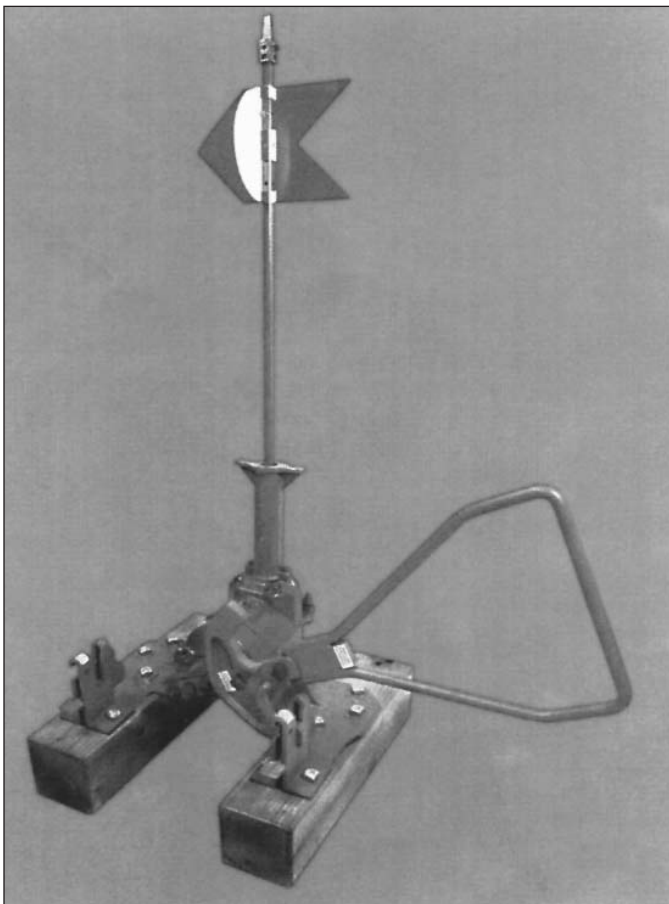

Automatic Operation for Accidental Trailing

The Models 22-E and 22-EH can be trailed or thrown manually. When a train runs through the switch, switch points are partially opened by the wheel flanges, and the throw is completed automatically. During automatic trailing, the target lamp rotates so that the switch point position is indicated, while the hand lever remains stationary.

Both models eliminate expensive repairs to stand, track and derailed equipment that result when a train runs through the switch with a rigid stand. An adjustable connecting rod and crank eye permit accurate setting of the points without respiking the stand.

Quality Components and Construction

The 22-E and 22-EH feature high quality components and construction, including extra heavy cast iron housings, as well as heat-treated working parts and oversized crank eye forged from SAE specification steel. The extra large bearing surfaces of the few wearing parts assure long life and a minimum of lost motion.

